



CodeMark 
CMNZ70014



CLELANDS TIMBER CODEMARKED

BEVEL BACK WEATHERBOARD MANUAL



CodeMark >>>
CERTIFIED



CodeMark is a voluntary product certification scheme that provides an easily-understood and robust way to show a building product meets the requirements of the New Zealand Building Code.

CodeMark is an unchallengeable form of product assurance. Building consent authorities (BCAs, usually councils) must accept a product certificate as evidence of compliance with the Building Code – that is, as long as the product is used in accordance with the use and limitations defined on the certificate.

TABLE OF CONTENTS

Scope	4	Proprietary System Components	10
Intended Use	4	Installation Preparation	10
Product Information	4	Framing	10
Performance	4	Horizontal Weatherboards	10
Wind Zones	5	Flexible Wall Underlay (Building Wrap)	10
Minimum Life	5	Rigid Wall Underlay	11
Serviceable Life	5	Drained Cavities	11
Coating and Priming	5	Packer cavity batten fixing method	11
Maintenance	5	Inter-Story Junction	11
Handling	5	Base of wall cavity	11
Resource and forestry certification	5	Top of wall cavity	11
Limitations	5	Internal and external corners	11
Critical System Components	6	Head Flashings	11
Paint Finish Weatherboards	6	Window and Door Joinery	12
Horizontal Bevel Back	6	Ground Clearance	12
Cavity Battens	6	Decking	12
Horizontal weatherboard systems	6	Meter Boxes	12
Rigid Wall Underlays / Rigid Air Barriers	6	Pipe Penetrations	12
Finishing Mouldings	6	Parapets / Enclosed Balustrade	12
Flashings	7	Installation Fixing Details	13
Fixings	8	Bevel Back	13
Fixing for paint finish weatherboards	8	Joins	27
Hand Driven Fixings Vs Nail gun	8	Corners	27
SCREW FIXING FOR PAINT FINISH WEATHERBOARDS	8	External Corners	27
Paint Finish Weatherboards	9	Contact Details	28
Things to expect	9	Disclaimer	28
Minimum maintenance	9		



INTENDED USE

Clelands Codemarked weatherboard system is designed for use as cladding for residential and small commercial buildings that fall within the scope of NZ3604. It is only suitable for buildings with a 'Risk Score' of 20 or below as per the 'Weather Tightness Matrix' outlined in E2/AS1. Refer to the Department of Building and Housing's booklet titled 'External moisture - a guide to using the risk matrix' for more information.

PRODUCT INFORMATION

Clelands weatherboards are produced from plantation grown Radiata Pine. When fingerjointed, this product exceeds its original physical and structural properties. The timber is kiln dried to between 8-14% moisture content for stability then machined to its finished form and treated using a light organic solvent preservative H3.1 or MCA H3.2 designed specifically for exterior applications. Once treated the timber is factory coated with an architectural primer. The MCA H3.2 treated option can also be stained rather than painted.

In low risk situations, Clelands weatherboards can be fixed directly to the studs - For Bevel Back

weatherboards when the risk score is 12 or below. For all situations when the risk score exceeds the above, cavity battens are required.

When using components not produced by Clelands such as flashings, sealants, paint etc. please at all times follow the manufacturer's recommended instructions. As the installation of the products rely on factors beyond Clelands control, Clelands assumes no responsibility for any work or systems used in conjunction with the installation of our products and their suitability to satisfy Building Codes or Council requirements.

PERFORMANCE

When installed and maintained as specified by a qualified tradesman using accepted trade practices it will meet the following requirements of the NZBC (New Zealand Building Code as contained in the Building Regulations Act 1992):

- B1 Structure
- B2 Durability
- E2 External Moisture
- F2 Hazardous Building Material

WIND ZONES

This solution is only acceptable for wind zones up to and including 'Very High' as defined in NZS3604. Extra High wind zones will require a rigid underlay and larger flashings.

MINIMUM LIFE

All weatherboards have minimum 15-year durability as required by NZS3602, given normal maintenance.

SERVICEABLE LIFE

In addition to the above minimum life, this H3.1 & H3.2 fingerjointed preprimed cladding system is expected to have a serviceable life of at least 30-years subject to installation, painting, coating and maintenance requirements as specified in this manual.

COATING AND PRIMING

Although these are factory-coated products, on-site finish coating will be required to achieve serviceable life span. All H3.1 preprimed products must be painted with two full coats of 100% premium acrylic topcoat to a minimum Dry Film Build of 60 microns (not including primer), within 4 weeks of installation.

Weatherboards must be dry before painting. Check board moisture content using a correctly calibrated moisture meter or measure board dimensions. If the board has greater dimensions than the profile specifications it is likely to have gained moisture. Moisture content should be 12-15%.

All coating is to be done according to coating manufacturer's instructions in a well-ventilated area. Refer to the coating/primer supplier for all matters relating to health and safety. All relevant sections of standard AS/NZS 2311:2009 (Guide to the painting of buildings) shall be adhered to.

Top coat colours should not be less than 45% light reflective values. Resin may bleed from timber in hot conditions or where painted in dark colours. We do not recommend the use of dark colours, high gloss or low sheen finishes.

Cutting & Sealing

When pre-primed weatherboard is cut there is no requirement to retreat, but you have to prime any cuts or ends with 2 coats of oil based primer.

The use of sealants between the Weatherboard laps will void any warranty of Clelands Timber Products Limited because this reduces ventilation, traps in any moisture and inhibits natural movement.

MAINTENANCE

The life spans specified apply to structural performance and weather tightness only. Appearance will degrade over time if maintenance requirements are not adhered to in accordance with the maintenance section of this manual

HANDLING

Weatherboards and accessories must be kept clean, dry, under cover and out of the weather prior to installation.

Timber must be stored horizontally on bearers at 1200mm spacing at least 150mm off the ground.

Wear dust mask, gloves, ear and eye protection when working with timber.

RESOURCE AND FORESTRY CERTIFICATION

All timber for Clelands Codemarked weatherboards is sourced from plantation forests in New Zealand. Generally the products are supplied as FSC (Forest Stewardship Council) Mixed Credit CoC certified.

LIMITATIONS

Clelands Codemarked weatherboards must be installed by a Licensed Building Practitioner.

This document is not exhaustive in its scope. Responsibility for design lies with the specifier or responsible party for the project to ensure the final design meets the requirements of the intended application and the NZBC.

For designs outside the scope of this technical specification, specific design must be undertaken by the architect or designer.

CRITICAL SYSTEM COMPONENTS

PAINT FINISH WEATHERBOARDS

HORIZONTAL BEVEL BACK

All profiles must have a minimum 32mm overlap, with matching opposed 8 x 6mm weather grooves 10mm from the edge of each edge. The exposed leading edge may optionally have a 3mm pencil round finish for better paint adhesion.

Profiles:

Standard WB/WBO - sizes 135 x 18mm, 142 x 18mm, 180 x 18mm, 187 x 18mm, 215 x 19mm, 230 x 19mm

Rebated WBR- sizes 135 x 18mm

Imperial WBB - sizes 140 x 21mm

Refer to Clelands Timber Products Ltd profile chart.

CAVITY BATTENS

Cavities must comply with E2/AS1 of the NZBC paragraphs 9.1.8 to 9.1.9.4.

Timber cavity battens shall be a minimum 45mm x 20mm to match the height of framing and be minimum H3.1 treated according to NZS3640.

HORIZONTAL WEATHERBOARD SYSTEMS

Use solid vertical cavity battens as follows: **20 x 45** or **20 x 65**

RIGID WALL UNDERLAYS / RIGID AIR BARRIERS

A Rigid Wall Underlay or Rigid Air Barrier (RAB) shall be included as part of the cladding system. In locations defined as Extra High wind zones according to Table 3 E2/AS1.

Where interior walls are not lined or for external walls of attached garages that are unlined and shall be installed according to Table 23 E2/AS1.

Where additional weather tightness of the building envelope is desired.

Approved RAB are to be minimum 6mm fibre cement sheet (e.g.: James Hardie, BGC).

Minimum 7mm H3.2 DD Plywood manufactured to AS/NZS2269 and tested in accordance with AS/NZS4284 (e.g. CHH Ecoply).

Rigid Air Barrier shall be fixed in accordance with the manufacturer's installation instructions and Clause 9.1.7 E2/AS1.

Rigid Air Barriers shall be independently appraised by an IANZ or similarly approved accreditation agency or testing facility.

FINISHING MOULDINGS

Clelands exterior shall be specified to match the relevant timber substrate and weatherboard system.

Mouldings shall generally be fixed with nails at a maximum 450mm centre position so as not to penetrate through flashings.

Mouldings shall have a continuous bead of sealant applied where they meet weatherboards, neighbouring mouldings or joinery.

Moulding available;

- Scriber
- Bevelled Cornice
- D4S
- Eaves Mould
- Internal Corner
- Cover Board
- External Corner

FLASHINGS

Flashings shall be made from Stainless Steel, Galvanised Steel, UPVC or Aluminium.

Soakers for all Bevel Back weatherboard may also be made from copper.

All flashing materials shall be compatible with neighbouring materials and comply with Tables 20, 21, 22 of E2/AS1 NZBC.

Flashings can be supplied by the timber merchant or by the builder according to this specification.

Weatherboard fixings shall not penetrate through the flashings under any circumstances as this may jeopardize the weather tightness of the cladding system.

(Note: Quickflash flashings codes are suggested here for reference only. Other flashing suppliers/brands may be used as long as they comply with the specifications in this manual).

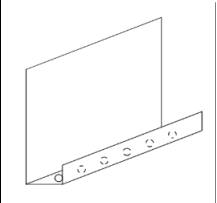
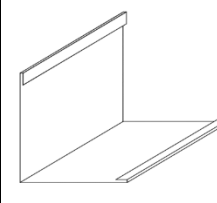
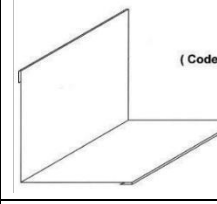
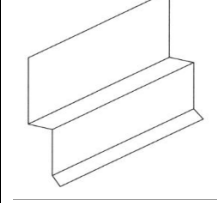
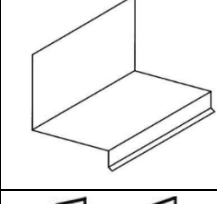
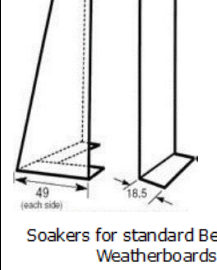
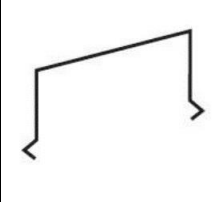
Quickflash Code http://www.quickflash.co.nz	
6 – 20mm Cavity Base Closer	
Hemmed Internal Corner Flashing 3 – 50mm, 40 – 70mm, 3 – 90mm	
Hemmed External Corner Flashing 14 – 50mm, 4 – 90mm	 (Code 04 shown)
21 – 40mm Z Flashing	
23 – Sill Flashing	
Bevel Back Corner and Flat Soakers	 Soakers for standard Bevel Back Weatherboards
107, 108 – Parapet Saddle Capping	

FIXINGS

For H3.1 product shall be in accordance with Table 24 of NZBC E2/AS1 and NZS3604 unless otherwise advised below.

For MCA H3.2 product shall be in accordance with NZ3604:2011 Tables 4.1 and 4.3. and shall be a minimum of:

- a) Type 304 stainless steel where used in exposed or sheltered locations (as defined in NZ3604:2011) or
- b) Hot-dipped galvanized steel for all other locations.

Fixings can be supplied by the timber merchant or by the builder according to this specification.

FIXING FOR PAINT FINISH WEATHERBOARDS

Shall be of the following specification:

Jolt head nail. Stainless steel, silicone bronze or hot dip galvanized. To allow minimum 35mm penetration into the framing (when using packer cavity battens) or 35mm penetration into the batten and framing combined (when using structural cavity battens).

HAND DRIVEN FIXINGS VS NAIL GUN

We recommend hand nailing for all Weatherboard fixings, a nail gun may be used as long as:

- It does not bruise/damage the weatherboard
- The correct nail size is adhered to as per our nailing guide.
- A non-marking attachment should be used to avoid damage to the board surface.
- There should be no damage to the surface of the timber from the driving pin of the nail gun

- There should be no damage to the back of the board from the nail being driven through
- Pre drill all boards 50mm from the end.

SCREW FIXING FOR PAINT FINISH WEATHERBOARDS

Quik-Drive SSDTH, Weatherboard Screws can be used as an alternative fixing method.

Simpson Strong-Tie Weatherboard Screws shall be installed into the weatherboards using the Simpson Strong-Tie Quik- Drive auto-feed screw driving system.

- The Weatherboard Screws feature self-drilling tips, box threads and a trim-head profile which facilitate the screws being installed into weatherboards without the need for pre-drilling in most instances.
- Accessory clip available for locating bottom of board provides consistent screw location.
- All screws shall be overdriven to countersink the screw heads by 3mm into the weatherboards sufficiently to allow for overfilling with exterior grade wood filler.

Simpson Strong-Tie Weatherboard Screws have been appraised by BRANZ for use to affix timber weatherboards to timber framing. Follow the link to find out more. <http://bit.ly/1044-19>

Minimum Required Fixing Sizes			
Profile	Direct Fix	Packer Cavity Batten	Packer Cavity with RAB
Bevel Back	75 x 3.15mm	90 x 4.0mm	-
Mouldings		40 x 2.80mm	40 x 2.80mm



PAINT FINISH WEATHERBOARDS

THINGS TO EXPECT

- Cladding in north facing or heavy weather exposed aspects age quicker than timber located in other aspects.
- Some movement of timber as it expands and contracts.
- Possible minor surface cracking (checking).

MINIMUM MAINTENANCE

- Cladding must be cleaned regularly (minimum every 12 months) with mild detergent and a soft brush, rinse with water. Note: High pressure water blasting is not allowed.
- A maintenance assessment is required at least every two summers as follows:
- Sand back areas of weatherboard where flaking or cracking is occurring. Putty and sand as appropriate, then spot prime and apply two coats of exterior paint as required.
- Check all weatherboards, junctions, flashings, mouldings and replace or remediate parts as required to maintain the weather tightness of the cladding system.
- Recoat the weatherboards with exterior paint as required by the coating manufacturer's recommendations (typically between 5 to 10 years).

PROPRIETARY SYSTEM COMPONENTS

These items are not supplied by Clelands. They shall be sourced and supplied by the timber merchant or the builder to a specification that conforms to NZBC requirements and are deemed fit for use in the end use application.

- **Flexible Sealant** – modified silicone exterior type.
- **Epoxy adhesive** – two pot exterior.
- **Flexible Wall Underlay (Building wrap) or rigid Wall Underlay** – to conform with Table 23 of E2/AS1.
- **PEF Backing Rod** – closed cell type designed for use as a backing rod, sized 25% larger than the gap it is to fill.
- **Flashing Tape** – compatible with other components in the system including the building wrap.

INSTALLATION PREPARATION

FRAMING

Generally, the timber framing must comply with NZS3604 (Timber-Framed Buildings), however where specific engineering design is required the framing shall be at least of equivalent stiffness to the framing provisions of NZS3604.

The moisture content of the framing must not exceed 18% at the time of fixing the weatherboard (problems may occur later due to excessive timber movement if framing is too wet).

Additional framing may be required at soffits, corners, window and door openings.

- Have polypropylene strap or wire applied to prevent bulging of wrap cavity in accordance with E2/AS1.
- Extend minimum 35mm over bottom plate.

HORIZONTAL WEATHERBOARDS

Studs must be spaced at a maximum of 600mm between centres.

Dwangs (noggins) must be spaced at a maximum of 1350mm between centres.

Studs and dwangs must form a flush plane for cavity battens and weatherboards to be fixed to.

FLEXIBLE WALL UNDERLAY (BUILDING WRAP)

A waterproof, breathable building wrap (e.g. WaterGate Plus) must be fixed underneath battens and weatherboards in accordance with Table 12 of E2/AS1 NZBC.

Flexible wall underlays shall also be:

- Fixed in accordance with 9.1.7.1 E2/AS1.
- Cut and dressed into openings in accordance with figure 72A and 72B E2/AS1.
- Have compliant and compatible flexible flashing tape applied to head and sill framing in accordance with E2/AS1.

RIGID WALL UNDERLAY

Rigid Wall Underlays/RAB's are required in Extra High wind zones according to Table 3 and 23 E2/AS1.

Rigid Wall Underlays shall be fixed in accordance with the manufacturer's installation instructions and Clause 9.1.7.2 E2/AS1 including:

- Sheet edges shall be fixed over solid framing with a 1-2mm expansion gap between sheets for fibre cement and 2-3mm gap for plywood. This may vary and must be verified with manufacturer's specification prior to installation.
- Shall have flexible underlay folded into opening reveals as per 9.1.5 a) E2/AS1.
- Shall be over-fixed with flexible wall underlay from Table 23 and installed in accordance with 9.1.7.1 E2/AS1 (note: some proprietary systems may not require this).
- Shall have flexible flashing tape applied to head, sill framing openings and all sheet joints including corners with a minimum 50mm lap to the RAB. Flexible tape must be compatible with the wall underlay and other surrounding materials.
- Shall extend past the bottom plate 15-25mm. This shall be confirmed with the RAB manufacturer prior to installation.
- Shall have flexible flashing tape to the RAB and overlapping the cavity closer at the bottom of the cavity.

DRAINED CAVITIES

Cavities shall comply with E2/AS1 of the NZBC paragraphs 9.1.8 to 9.1.9.4.

PACKER CAVITY BATTEN FIXING METHOD

Temporarily fix 20 x 45mm battens with fixings at 800mm centres with:

- 40 x 2.5mm flat head, hot dipped galvanised nails; or
- 50 x 2.8mm 'D' flat head, power-driven, galvanised nails.

INTER-STORY JUNCTION

An inter-story junction shall be used for continuous cavities over two stories or 7 metres.

A 'Z' flashing shall be used with at least 35mm cover over the weatherboard and with a minimum 15 degree fall and allowing 5mm minimum gap between flashing and weatherboard in accordance with E2/AS1.

BASE OF WALL CAVITY

The base of walls including above window heads and inter-story flashings:

- Shall have a cavity base closer with minimum ventilation area 1000mm² per metre length.
- The cavity closer shall be positioned to allow at least 10mm drip edge to wall cladding or 15mm above window and door head flashings, in accordance with 9.1.8.3 E2/AS1.

TOP OF WALL CAVITY

Shall be sealed off using a solid (non-castellated, non-Cavibat) vertical cavity batten running horizontally.

INTERNAL AND EXTERNAL CORNERS

Shall have vertical cavity battens fixed with at least 10mm gap between battens.

HEAD FLASHINGS

Shall be fixed with a flashing upstand of a minimum 35mm cover with tape or underlay lapped over the flashing.

Extra High wind zones shall have a minimum 75mm cover flashing to head flashing upstand and extend a minimum 60mm over the weatherboard.

Shall have a minimum 15 degree fall with 5mm gap between head flashing and weatherboard in accordance with E2/AS1.

Shall be fixed with stop ends, with 30mm cover and, if scribes are used, extend 20mm past the scribe in accordance with E2/AS1.

Shall have air seals between reveal or frame in accordance with 9.1.6 E2/AS1, installed with self-expanding polyurethane foam over PEF backing rod.

May be timber or aluminium.

Shall meet the requirements of NZS4211.

Shall be designed in accordance with the relevant wind zone.

Shall meet the requirements of E2/AS1.

Shall have sill support bars installed in accordance with E2/AS1 and where possible sill trays are recommended.

Shall have flexible flashing tape around openings and over cavity closer above joinery head.

Jamb shall be scribed with scribe sealed to weatherboards and be made weather tight with a foam bond break and a continuous bead of sealant along the jamb line.

Shall have flexible air seal all sides of joinery penetration, comprising self-expanding polyurethane foam or sealant installed over closed PEF backing rod.

For Very High and Extra High wind zones, the head flashing shall be sealed to the window flange in accordance with E2/AS1.

GROUND CLEARANCE

Ground clearance between bottom of cladding and the ground shall be in accordance with 9.1.3 and Table 18 E2/AS1. The base of the cladding shall:

- Overlap the concrete slab by a minimum 50mm.
- Finish 100mm above a paved surface.
- Finish 175mm above an unpaved surface.

The ground shall have a slope of at least 1:30 to allow water to flow away from the building.

DECKING

Refer to E2/AS1 for requirements specific to the type of decking being used.

- Where cladding finishes above a deck it shall finish minimum 35mm above a decking surface and have a 10mm drip edge.
- Where cladding finishes next to slatted decking there shall be at least a 12mm gap between the decking and cladding wall surface

WINDOW AND DOOR JOINERY

METER BOXES

Shall be manufactured from durable, UV resistant, non-combustible material with minimum 20 year service life expectation.

Shall be designed with sills so as to allow water to easily drain away from possible entry points.

Shall have flashing tape around the entire opening.

Shall have the building wrap overlapping the 'Z' head flashing, and with the flashing to be riveted and sealed to the top metre box flashing with a minimum 10mm overlap.

Shall be sealed around all sides with self-expanding polyurethane foam over PEF backing rod.

PIPE PENETRATIONS

Shall be in accordance with 9.1.9, 9.1.9.1, 9.1.9.3 and figure 68 E2/AS1.

Pipes shall be installed with a 5 degree fall, with appropriate support noggin underneath.

Shall use an appropriate pipe flashing approved by Clelands Timber or flashing tape to seal the pipe to the building wrap or RAB in accordance with E2/AS1.

Shall have sealant applied over PEF rod to make penetrations through both weatherboard and interior lining weather tight.

PARAPETS / ENCLOSED BALUSTRADE

Capping shall have minimum 50 year durability and shall have 'birds beak' style drip edge.

Fixing penetrations through the capping shall be made through the side only.

Capping shall be separated from timber by roof underlay or other suitable material.

The slope of the cap shall be a minimum of 5 degrees.

The capping shall overlap the weatherboards by:

- 50mm – Low to High Wind Zones
- 70mm – Very High Wind Zones
- 90mm – Extra High Wind Zones

Expansion joints may be required for lengths over 8m – refer to E2/AS1.

INSTALLATION FIXING DETAILS

BEVEL BACK

- Fixings shall be driven through the wall underlay and in the framing in accordance with Table 24 E2/AS1.
- Fixings shall be hand driven, or as per section 2.6.2
- Weatherboards shall be predrilled prior to application of fixing with a drill bit slightly smaller than the fixing.
- Nail placement shall be 10mm above the lap.
- The lap between boards shall be 32mm.
- Opposing weathergrooves shall be lined up to form an 8 x 10mm weathergroove.
- Nails should be applied at an upward angle so as to reduce water ingress through the fixing point.
- Weatherboards shall be fixed to framing at maximum 600mm centres.
- Weatherboard fixings shall not penetrate through the flashings under any circumstances as this may jeopardise the weather tightness of the cladding system.

Refer to architectural drawings for further Bevel Back fixing details.

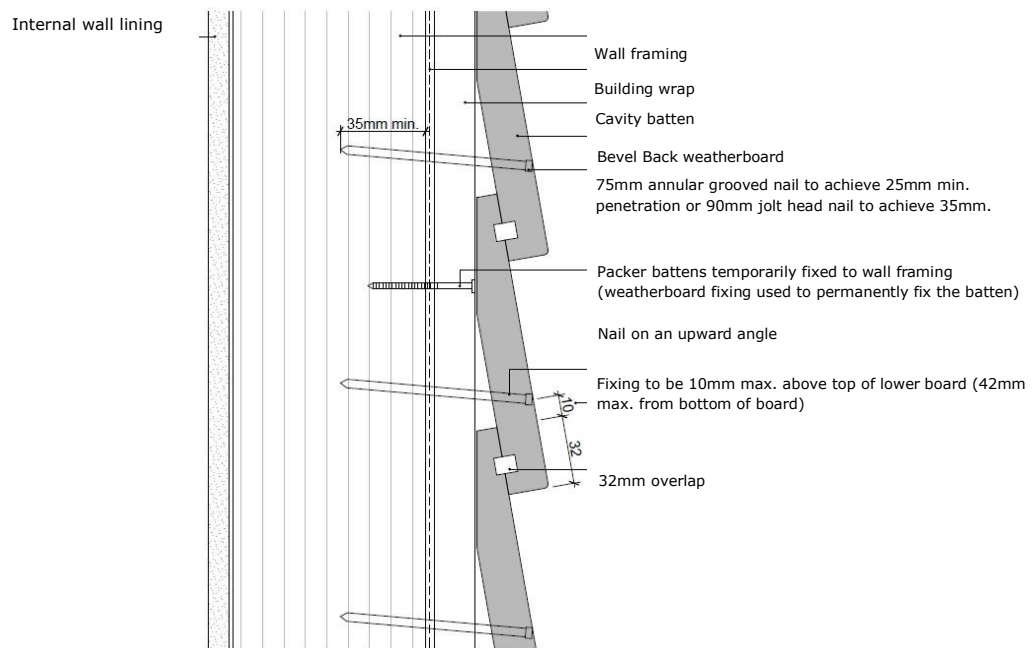
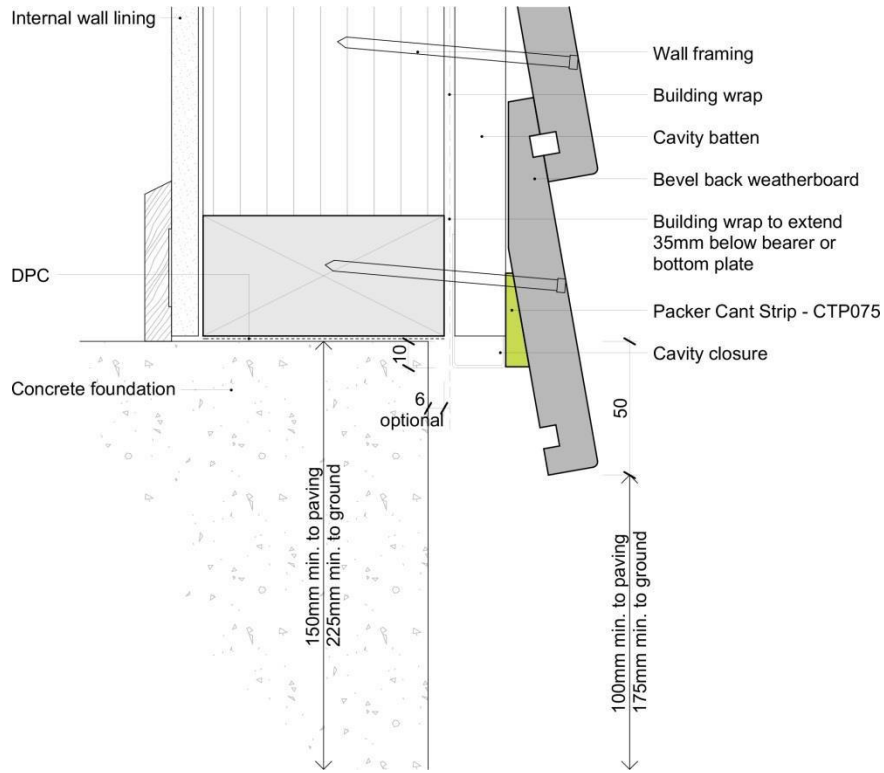
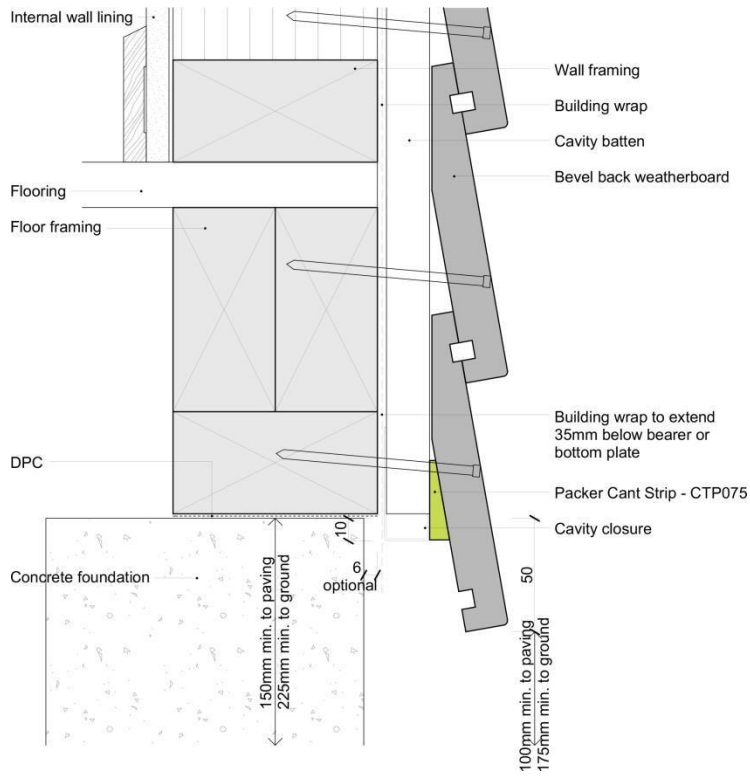

Figure 1 Bevel Back Fixing



Bevel Back – Base Of Wall - Concrete Floor



Bevel Back – Base Of Wall - Timber Floor

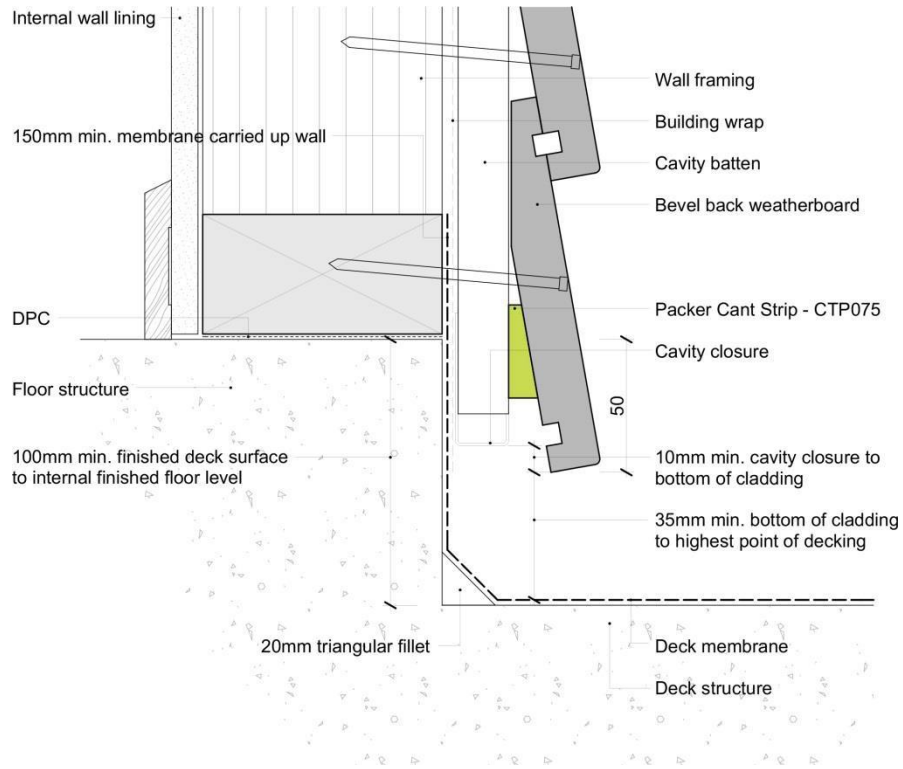

Bevel Back – Enclosed Deck – Concrete Substrate

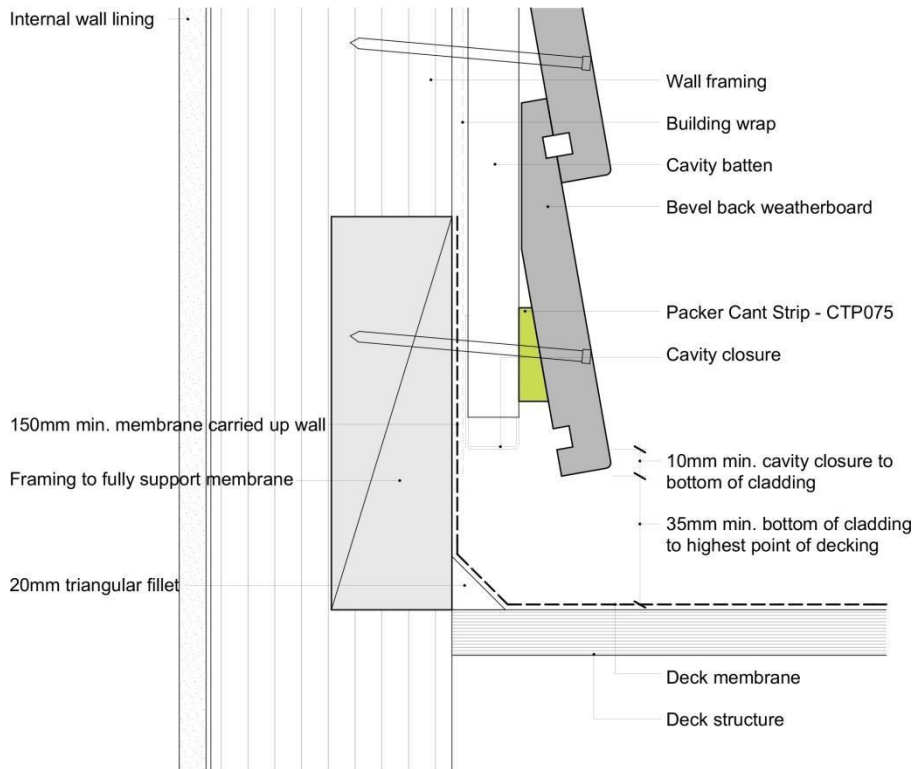

Bevel Back – Enclosed Deck – Timber Substrate

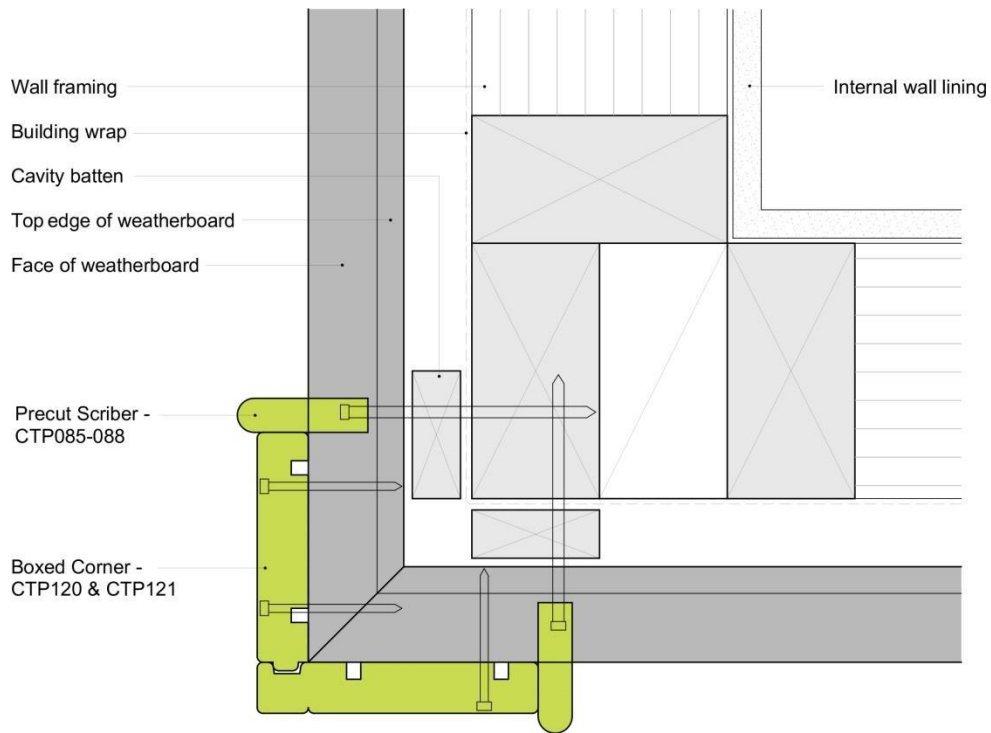

Bevel Back – External 90° Corner – Boxed

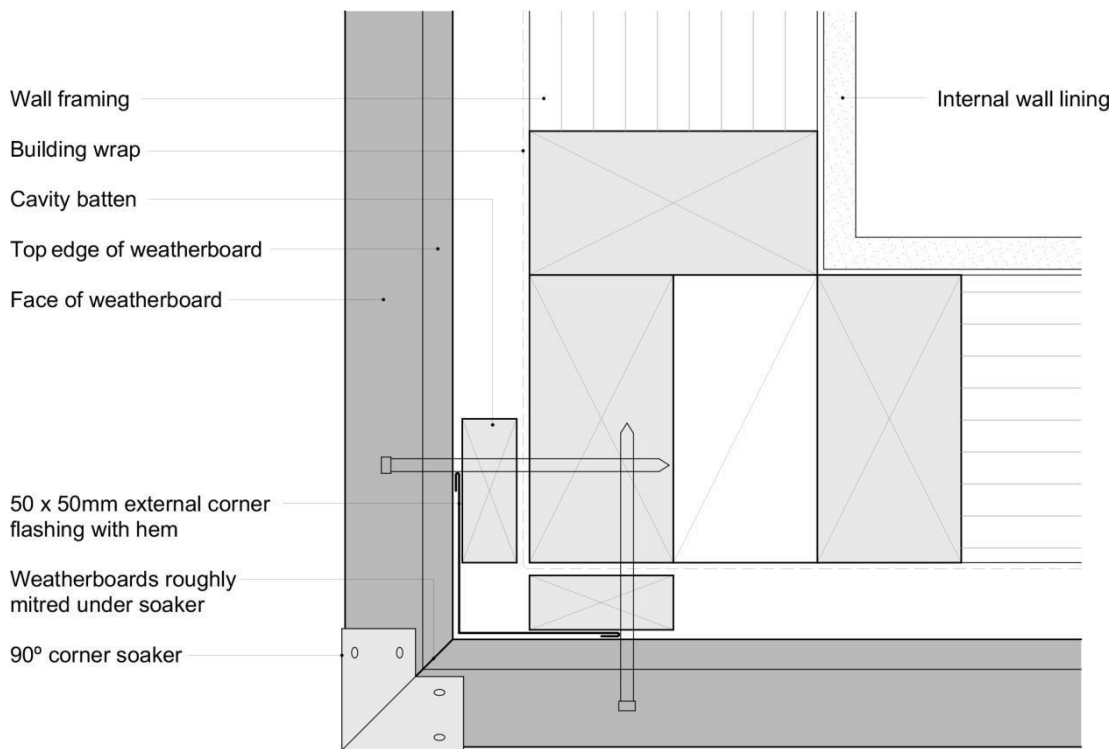

Bevel Back – External 90° Corner – Soakers

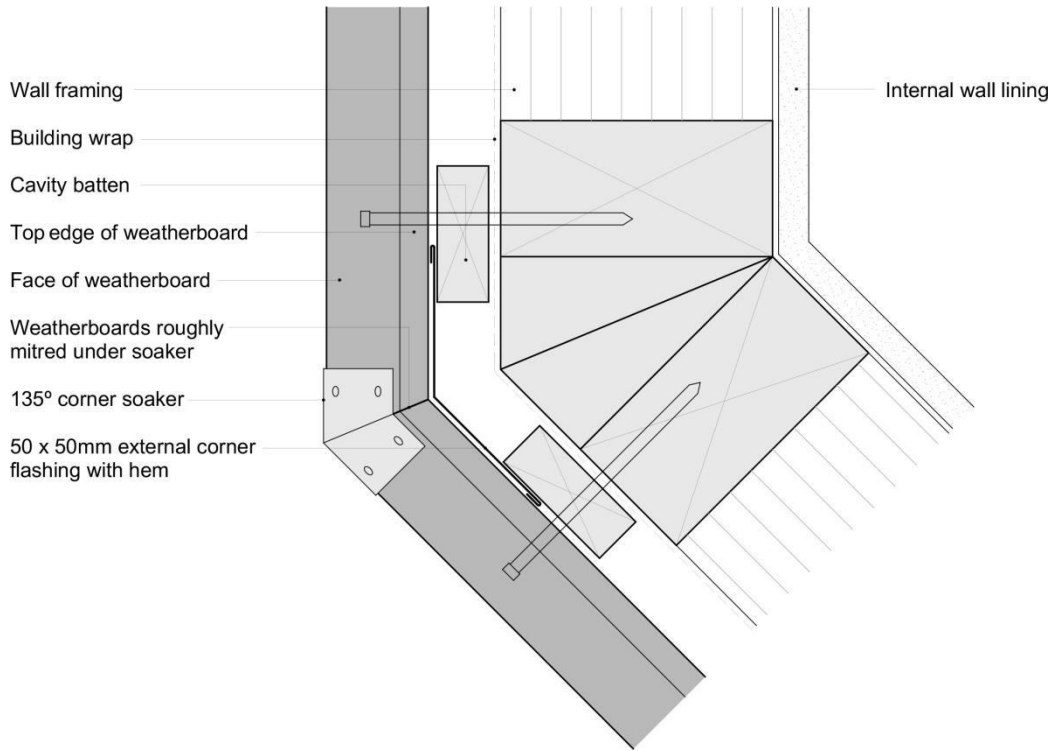

Bevel Back – External 135° Corner – Soakers

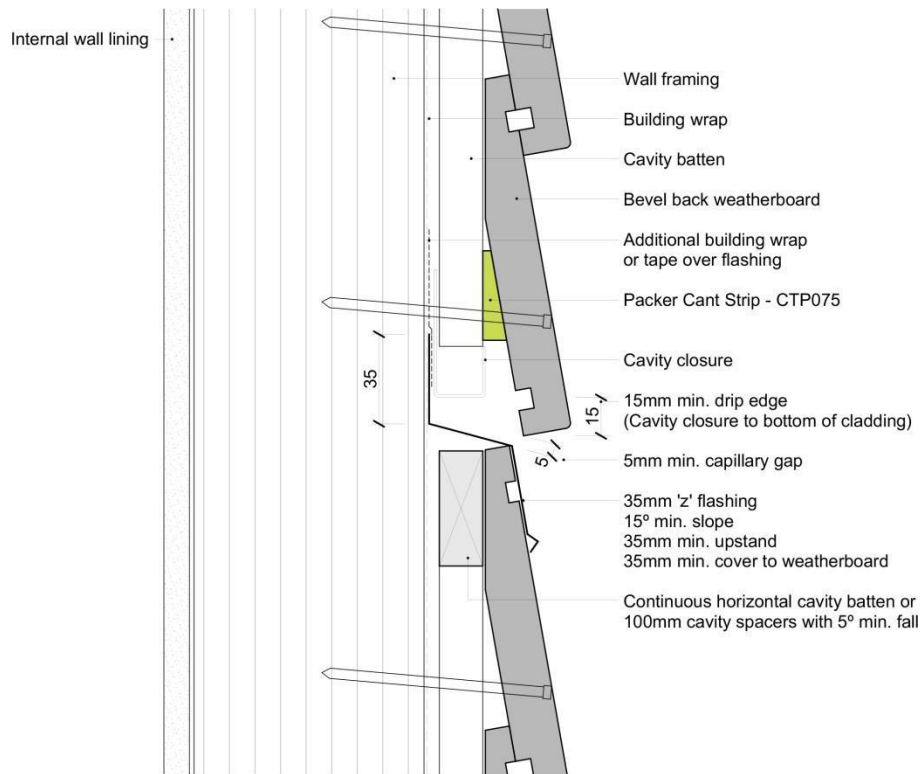

Bevel Back – Inter-Storey Cavity Junction

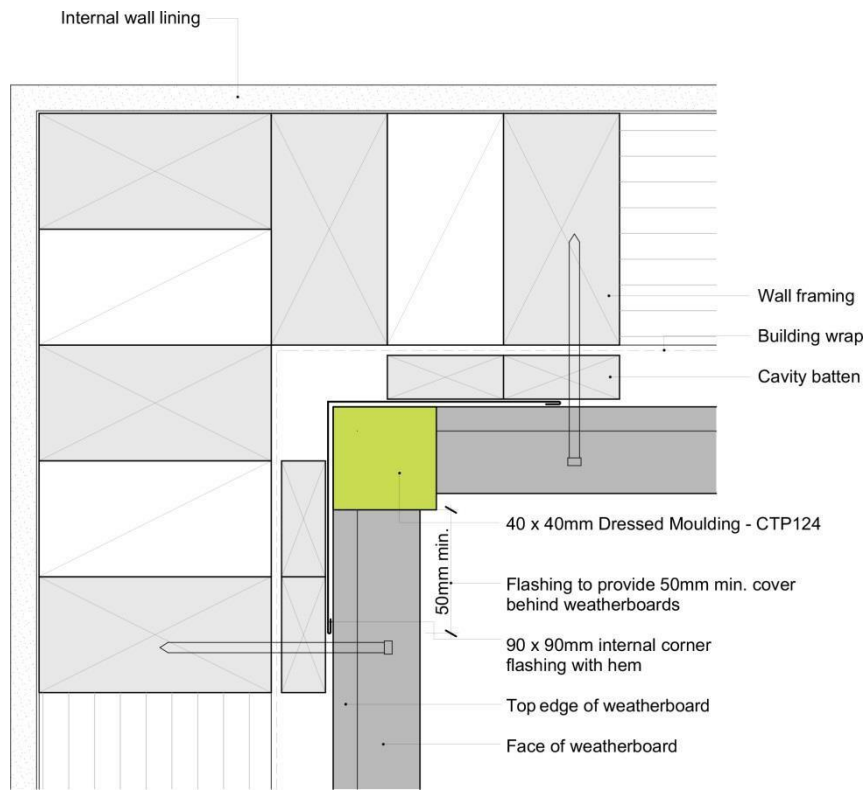

Bevel Back – Internal 90° Corner - Moulding

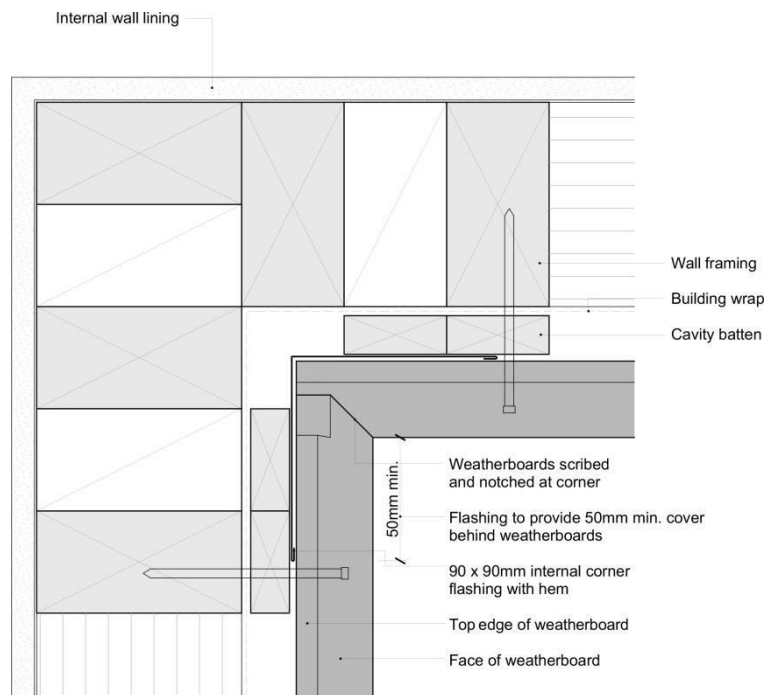

Bevel Back – Internal 90° Corner - Scribed & Notched

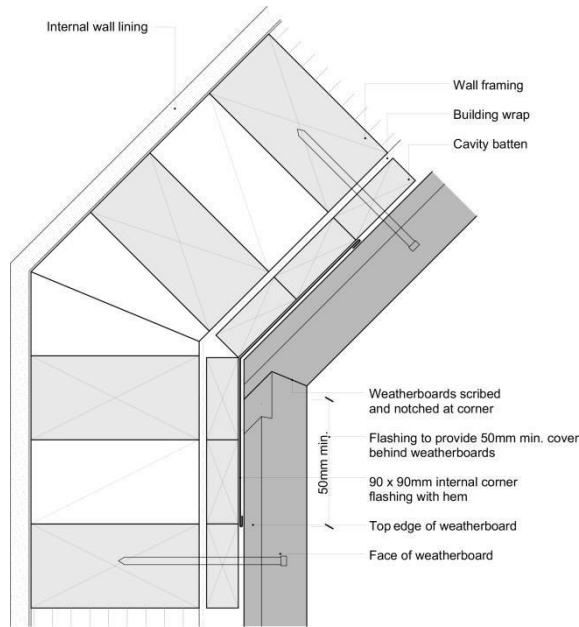

Bevel Back Internal 135° Corner - Scribed _ Notched

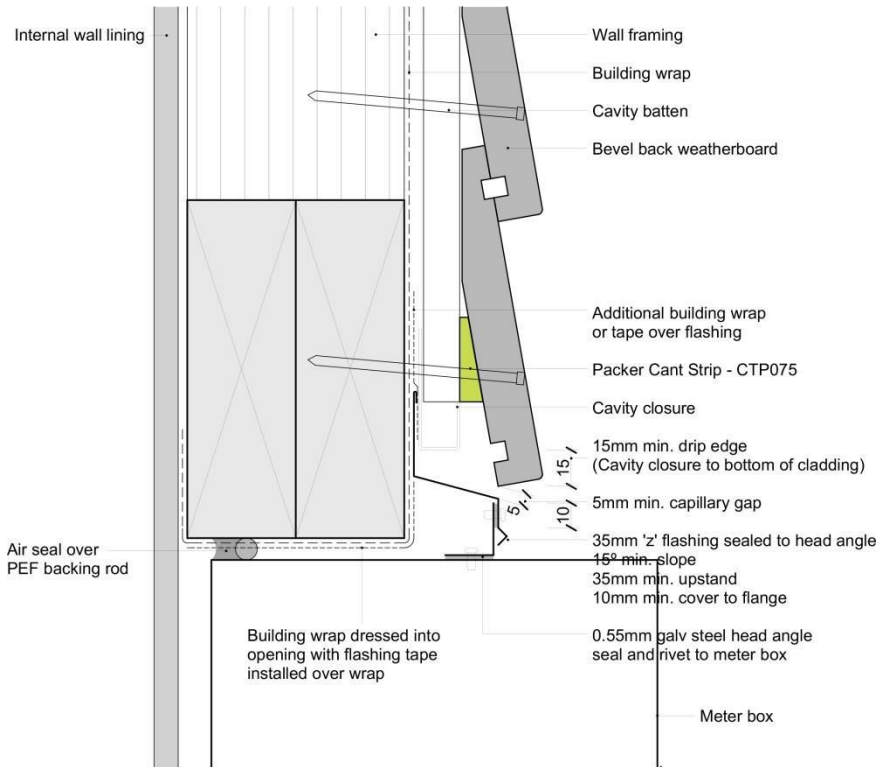

Bevel Back – Meter Box Head

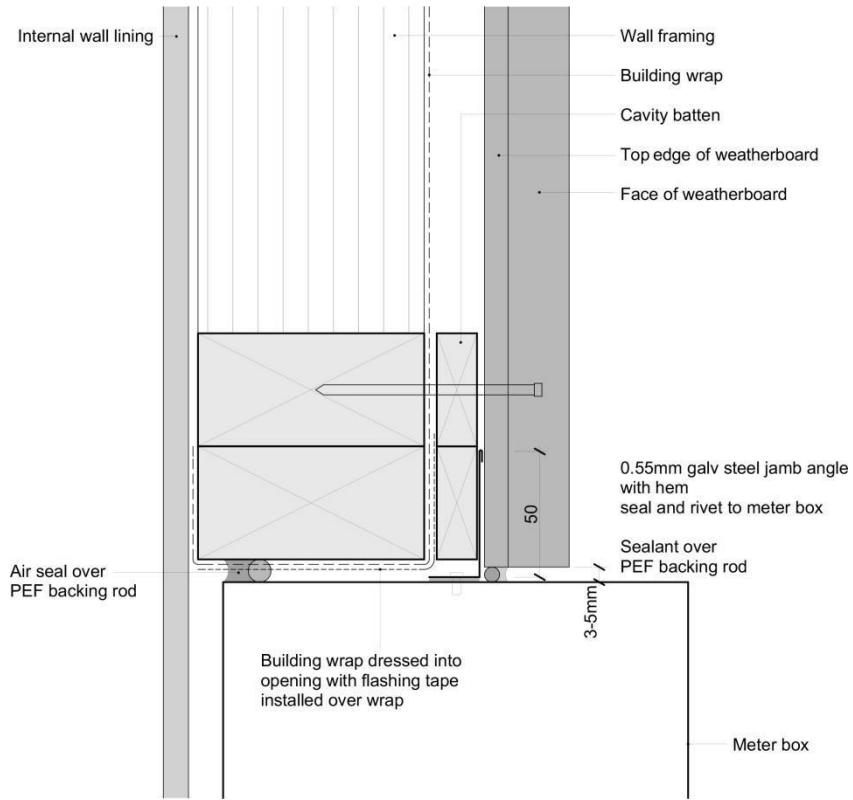

Bevel Back – Meter Box Jamb

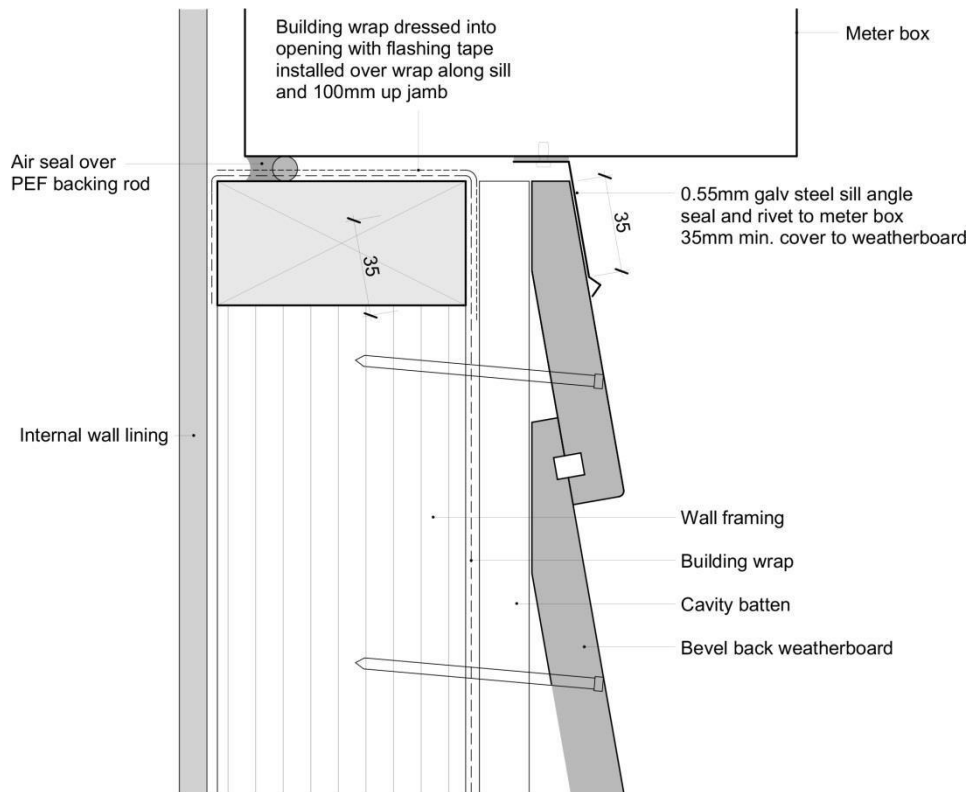

Bevel Back – Meter Box Sill

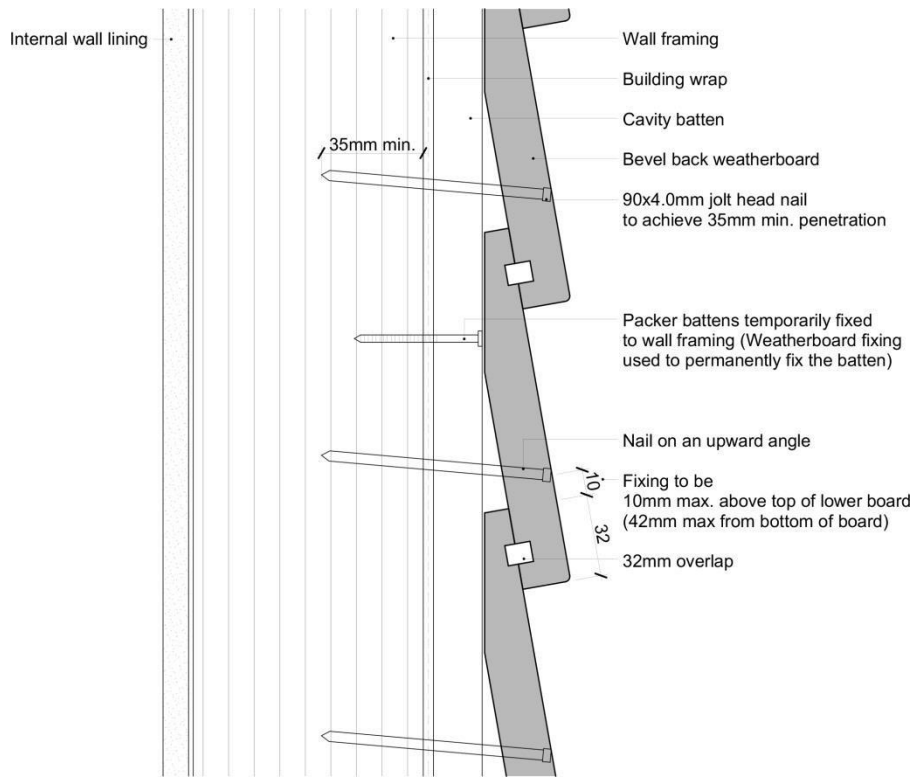

Bevel Back – Packer Cavity Batten

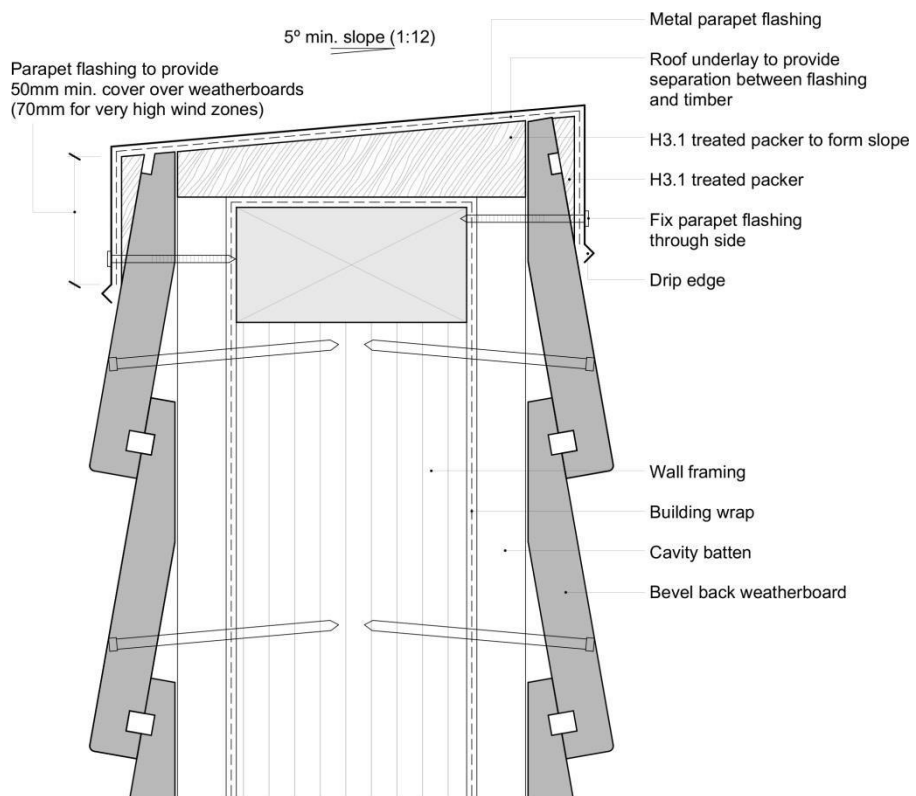

Bevel Back – Parapet Balustrade Cap Flashing

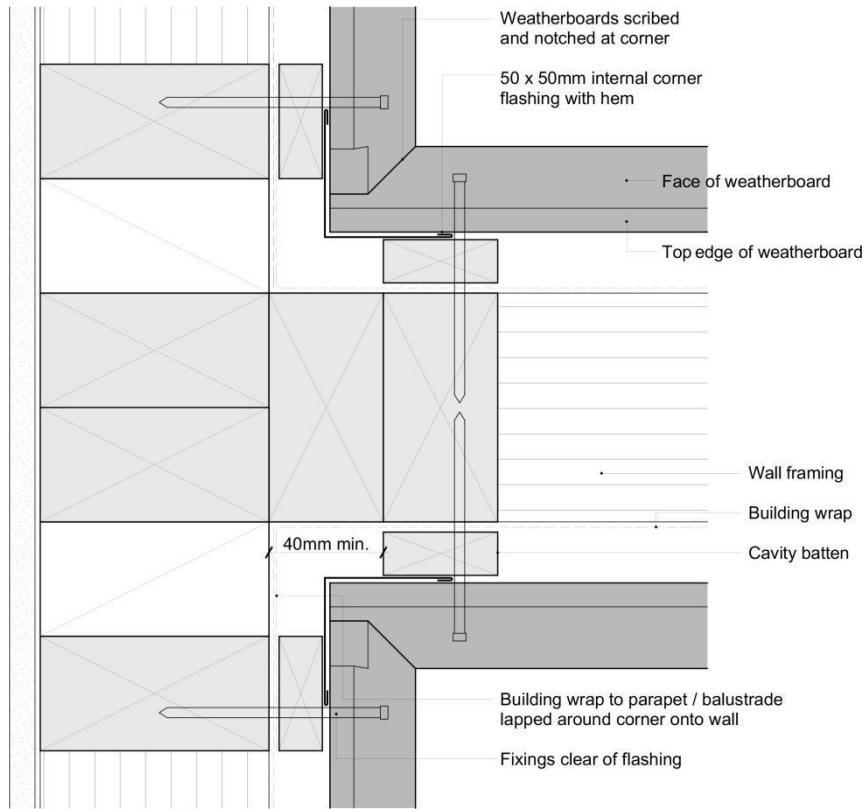

Bevel Back – Parapet Balustrade Intersection With Wall – Scribed & Notched

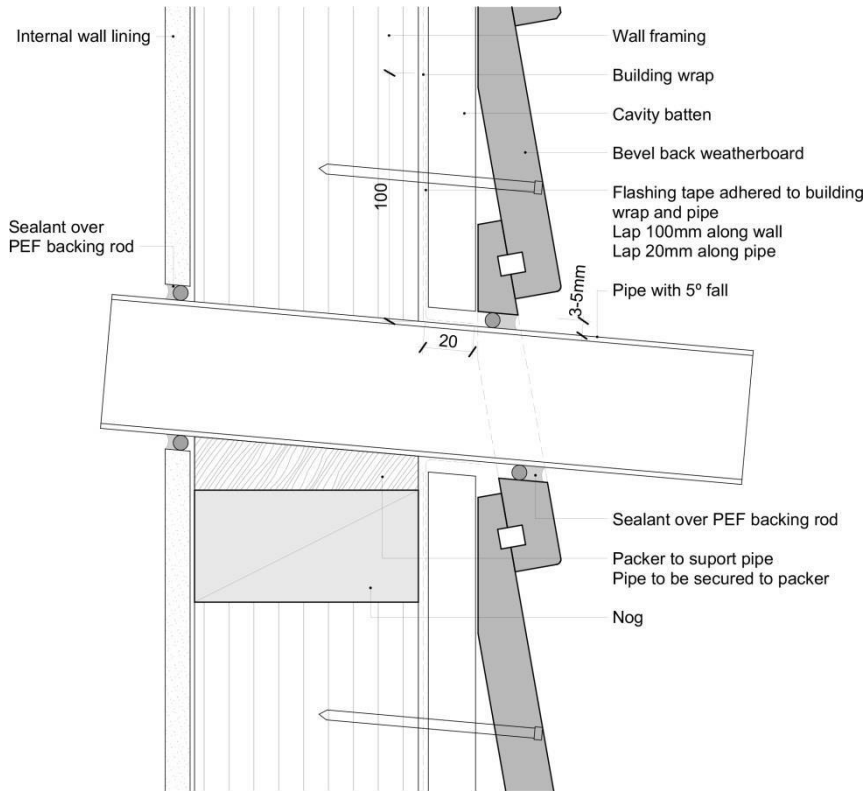

Bevel Back – Pipe Penetration

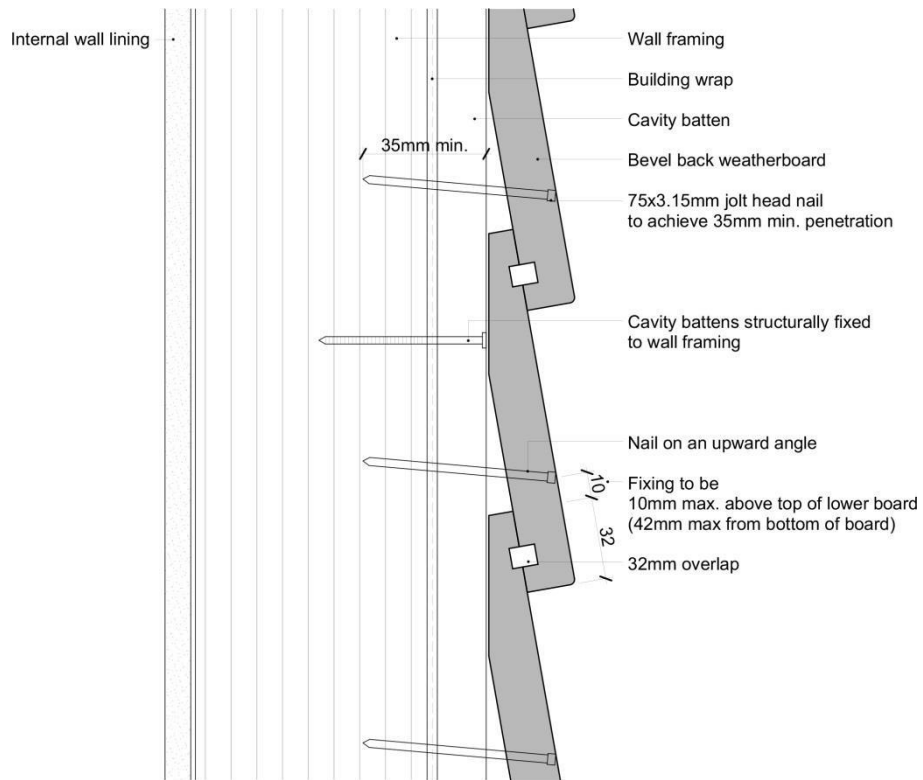

Bevel Back - Structural Cavity Batten



Bevel Back - Top Of Wall - Flat Soffit

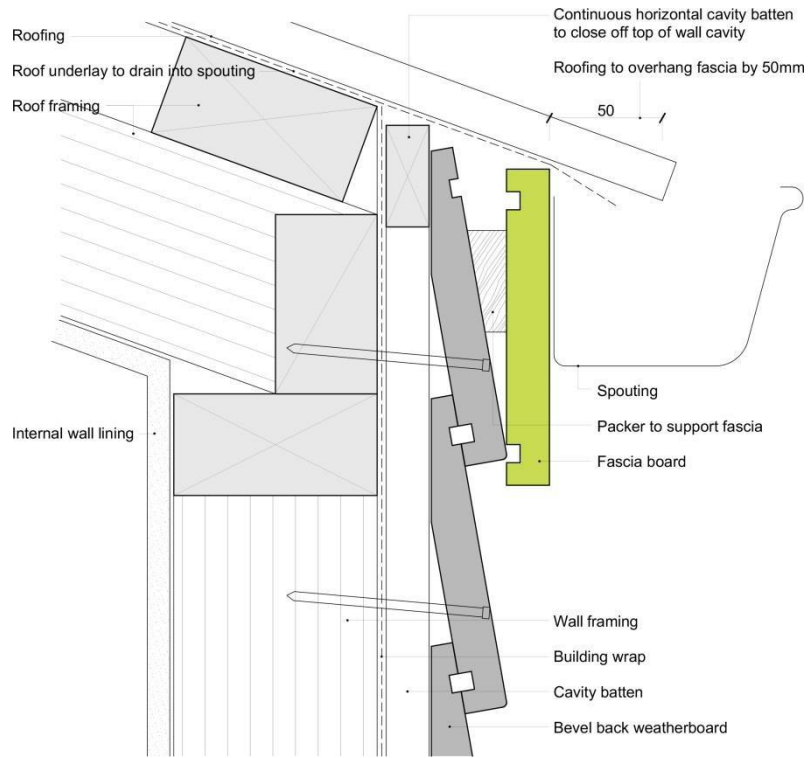

Bevel Back – Top Of Wall – No Soffit

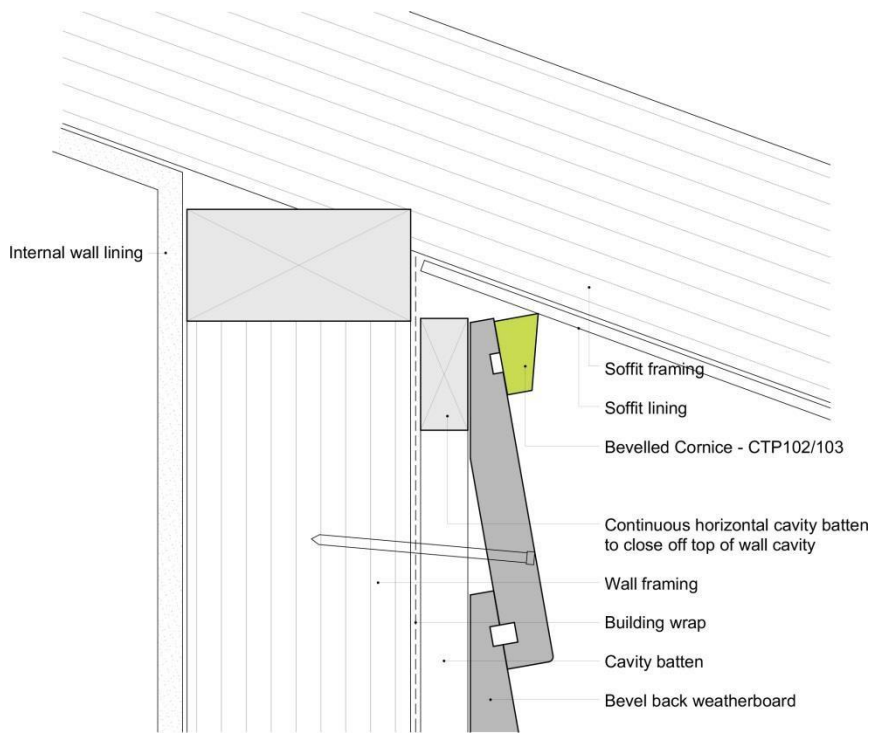

Bevel Back – Top Of Wall - Sloping Soffit

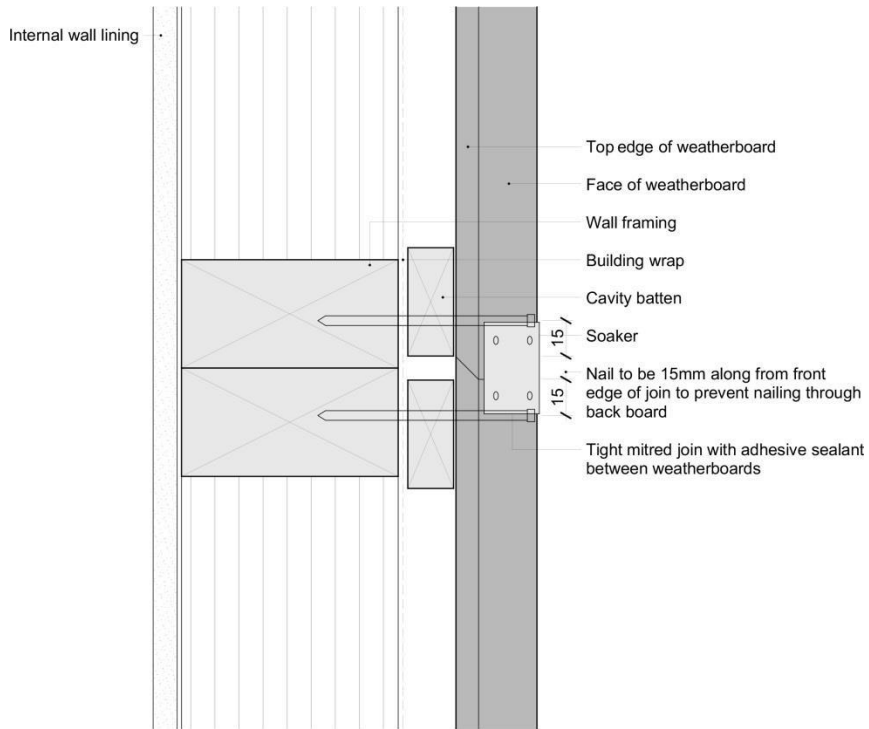

Bevel Back – Weatherboard Join

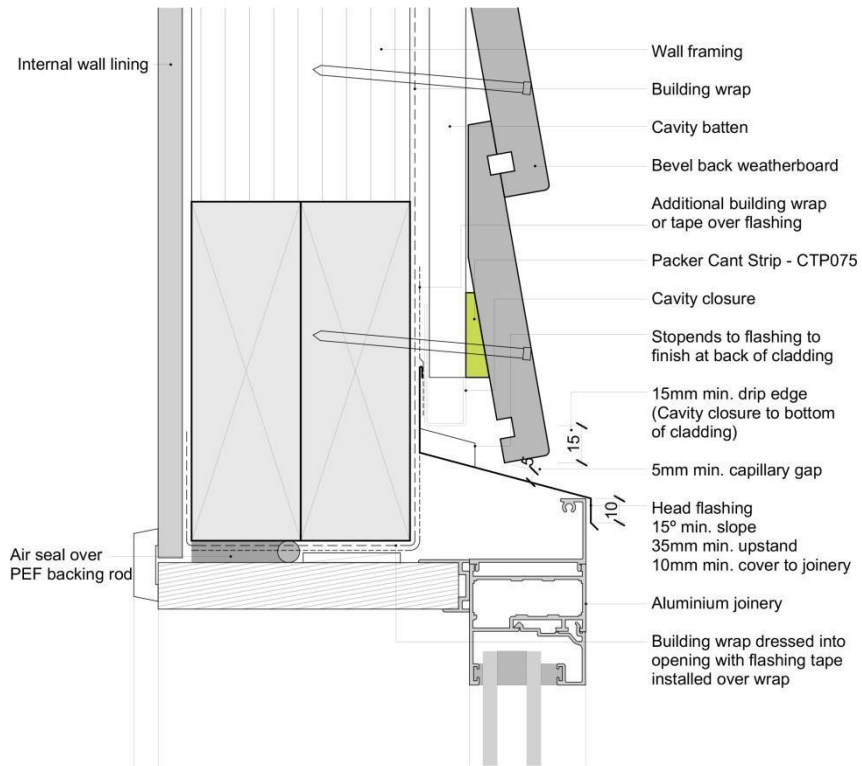

Bevel Back – Window Head

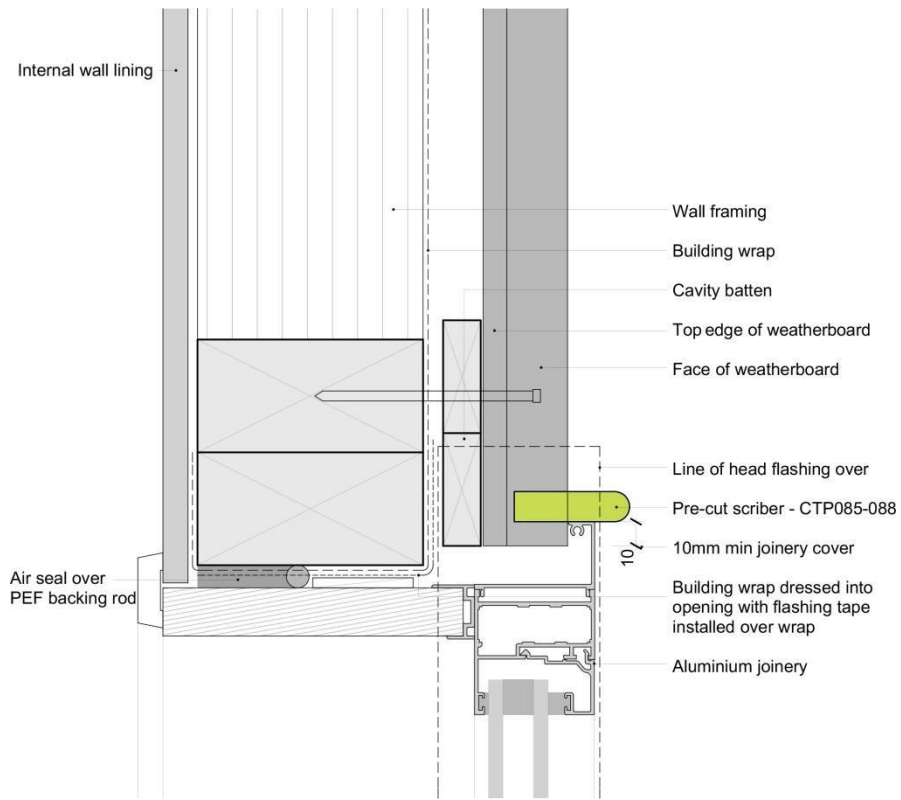

Bevel Back – Window Jamb

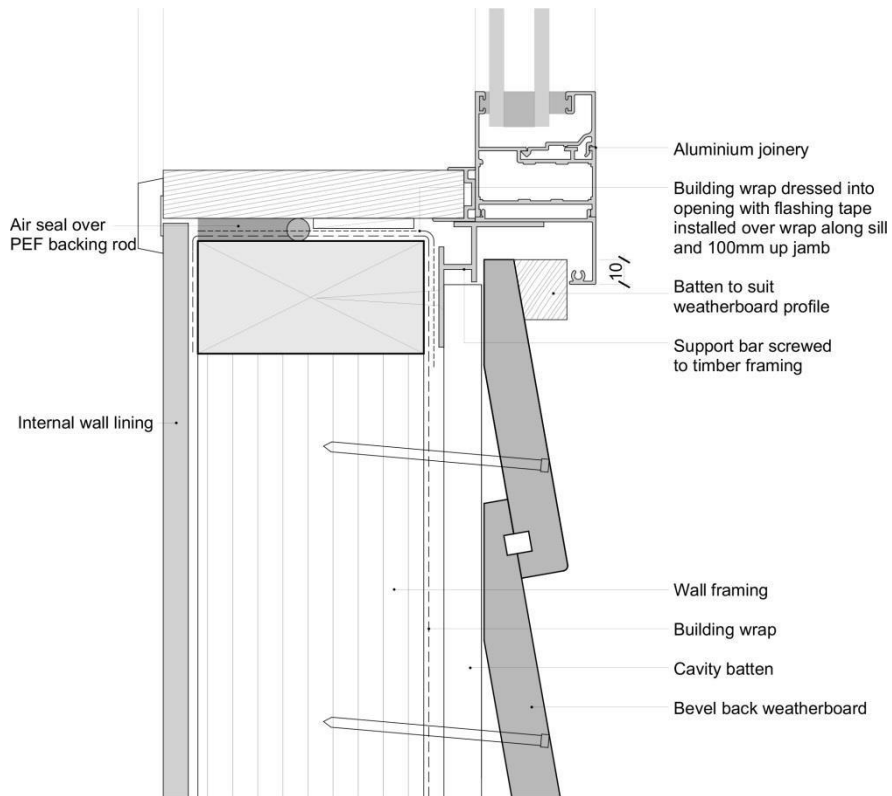

Bevel Back – Window Sill

JOINS

Scarf joints shall be mitred and made over battens only with one nail applied either side of the joint predrilled at least 12mm from the ends. The joint shall have sealant applied and be covered with a corrosive resistant flat soaker. Joints shall be staggered by at least 600mm.

CORNERS

Shall be made weather tight with hem folded 50 x 50 or 70 x 70 or 90 x 90 flashings according to the type of corner being used and the wind zone.

Shall be either:

- Scribed and notched with 90 x 90mm hem folded corner flashing; or
- Butted to 40 x 40mm internal corner mould with 90 x 90 hem folded corner flashing.
- A continuous bead of sealant shall be applied where mouldings meet weatherboards and neighbouring mouldings or joinery.

EXTERNAL CORNERS

Shall be made weather tight with hem folded 50 x 50 or 70 x 70 flashings.

Shall be either:

- Mitred and covered with corrosion resistant soakers with 50 x 50 hem folded flashing; or
- Covered with external cover boards in conjunction with scribes.
- A continuous bead of sealant shall be applied where mouldings meet weatherboards and neighbouring mouldings or joinery.

CONTACT DETAILS

Clelands Timber Products Limited

61 Katere Road, PO Box 3240, New Plymouth 4341

Ph: 0800 100 095 | Fax: 0800 114 488 | www.clelands.co.nz | sales@celands.co.nz

DISCLAIMER

The recommendations contained in this document are based on good building practice but are not an exhaustive statement of all relevant information. The successful performance of the system relies on many factors outside the control of Clelands Timber Products Ltd such as the quality of workmanship and design. Clelands Timber Products Ltd shall not be liable for the recommendations made in its literature and the performance of the system including conformance with the NZBC, regulations and standards. It is the responsibility of the building designer to ensure that the details and recommendations provided are suitable for the intended project and that the design is executed appropriately.